

PRODUCT OVERVIEW

Manual pulse generator (hereinafter referred to as MPG) for CNC machine tools in the origin setting, manual stepping fine-tuning, processing interruptions and insertion, etc., the product is divided into: SS, SE, SM, SF four major series, can be widely used in CNC machine tools, printing machinery, automation systems and so on.

FEATURES IN BRIEF

- ◆ Humanized design, more comfortable handfeeling and more beautiful appearance;
- ◆ High-performance core encoder, non-contact optical detecting structure, accuracy unchanged after millions of times of use;
- ◆ Built-in strong magnet, base type hanging box, more convenient and firm to place;
- ◆ High-quality standard spring cable, guaranteed 200,000 times stretching;
- ◆ Optional emergency stop, enable, add manual and quick buttons;
- ◆ Wireless portable MPG adopts 433M wireless transmission technology, encrypted transmission and anti-interference;
- ◆ Shielded design, anti-electromagnetic interference;
- ◆ Adopts anti-interference, wear-resistant, oil-resistant and drop-resistant design;
- ◆ Can be customized according to customers' requirements.



MODEL SELECTION INSTRUCTIONS

Series Code	Selection of Axes	Operating Voltage	Output Pulse	Switching Mode	Cable Length	Connectors	Emergency Stop Switch	Enable Switch
SE	2:OFF.X.Z	1:5V voltage output	25P/r	D: Corresponding type	0: No cable	P: Straight Connector	E: ne-way emergency stop	S: Enable switch
SS	3:OFF.X.Y.Z	2:5V differential output	100P/r	B: Coding type (Total 24V)	3: 3M	P1: 90° Connector	E2: Two-way emergency stop	No labeling & none
SM	4:OFF.X.Y.Z.4	3:12V voltage output		B0: Coding type (Total 0V)	5: 5M(default)	Empty: NO Connector	No labeling & none	
SF	5:OFF.X.Y.Z.4.5	4:24V voltage output			10: 10M	P/XXM: Socket solder wire		
	6:OFF.X.Y.Z.4.5.6							
	7:X.Y.Z.4.5.6.7							

EXAMPLES OF MECHANICAL & ELECTRICAL CHARACTERISTICS

Model No.	SE-31-100-D	SS-42-100-B	SM-54-100-B0	SF-43-25-D
Applicable systems	Fanuc/domestic system	Siemens/Fagor	Siemens PLC/PLC	Mitsubishi
Pulse output	100P/r	100P/r	100P/r	25P/r
Scope of supply	DC5V ± 5%	DC5V ± 5%	DC24V ± 5%	DC12V ± 5%
Axis selection	OFF、X、Y、Z	OFF、X、Y、Z、4	OFF、X、Y、Z、4、5	OFF、X、Y、Z、4
Membrane switch	3 bits.	None	None	None
Magnification	3-4 gears	3rd gear	3rd gear	3rd gear
Switching output method	Corresponding type	Coding type (total 24V)	Coding type (total 0V)	Corresponding type
Frequency response	0~20kHz			
Isolation resistor	≥20MΩ			
Operating temperature	-10~+60℃ (without freezing)			
Output form	Voltage output	Differential output	Voltage output	

RELATIONSHIP BETWEEN WAVEFORM OUTPUT VS. SCALE POSITION

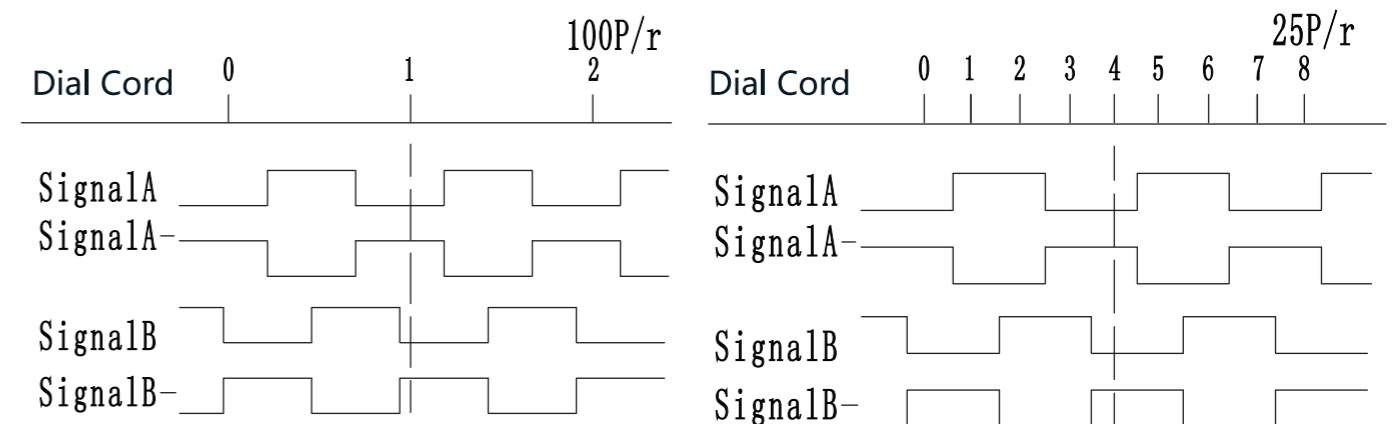

SPRING CABLE SPECIFICATIONS

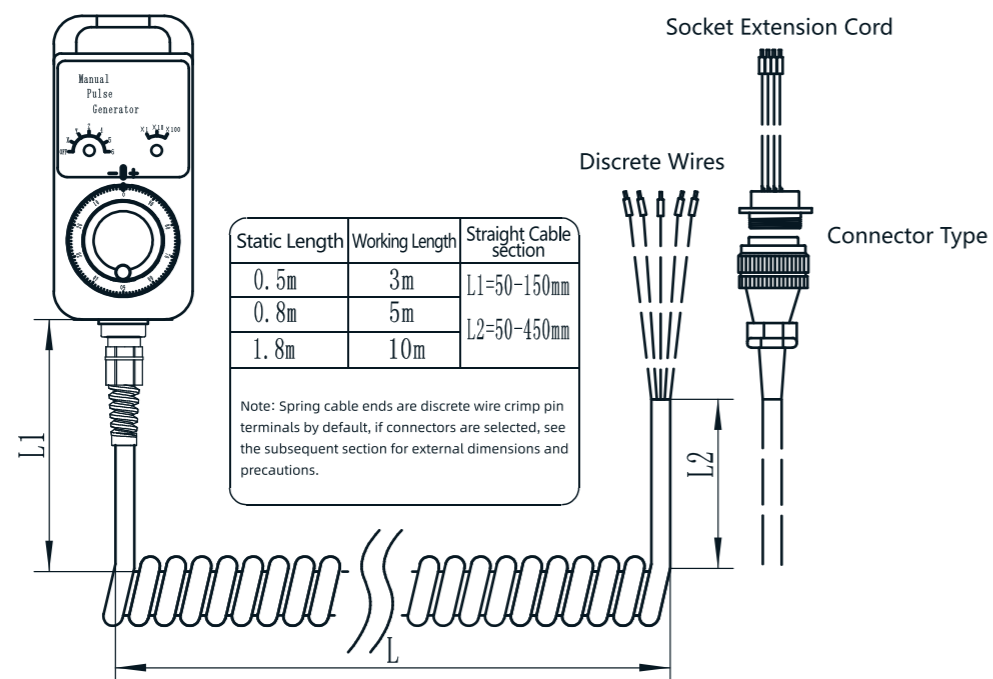

CONNECTOR SPECIFICATIONS

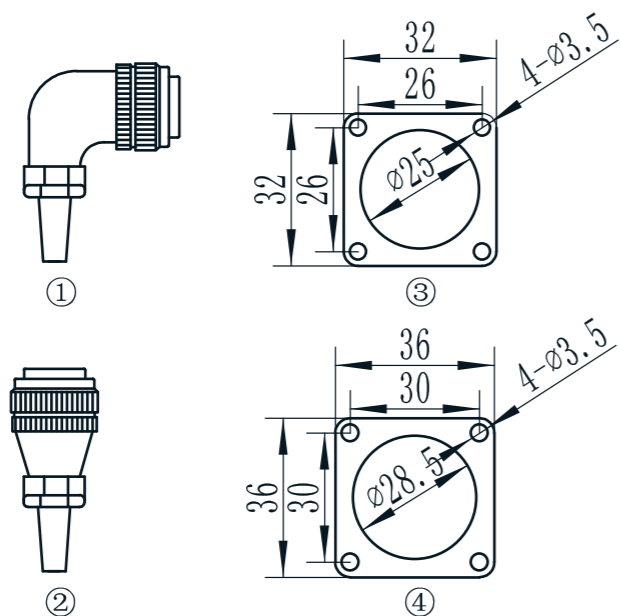

① : 90°Connector ② : Straight Connector

③ : 19-pole Socket Opening Size ④ : 20, 24 & 26-pole Socket Opening Size

Note: See drawing for special connector dimensions

DIMENSION APPEARANCES

SS Series

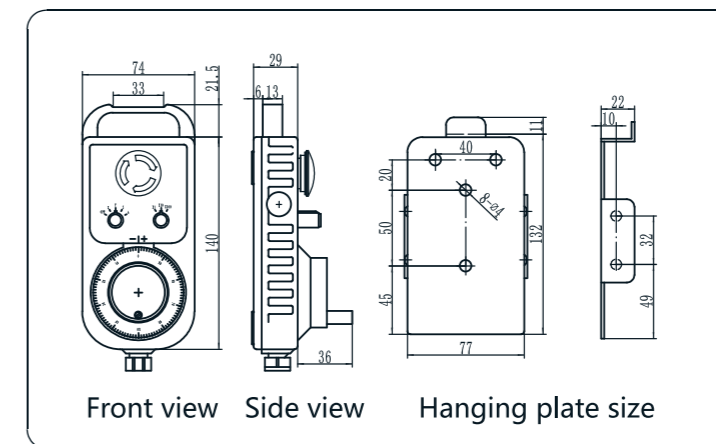

SE Series

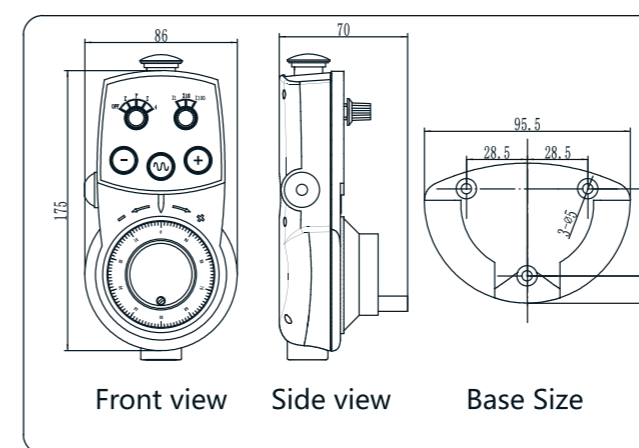

SM Series

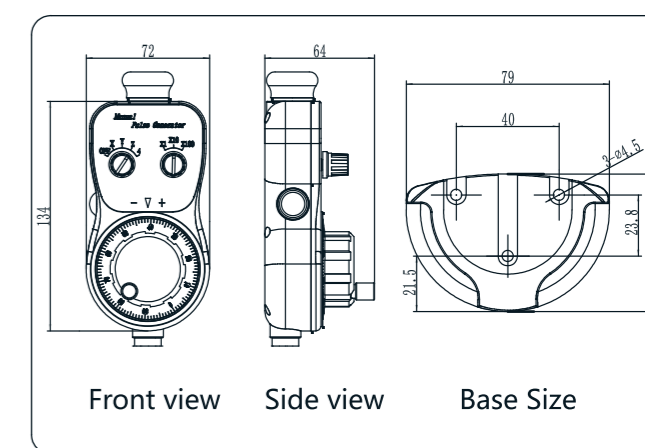

SS Series

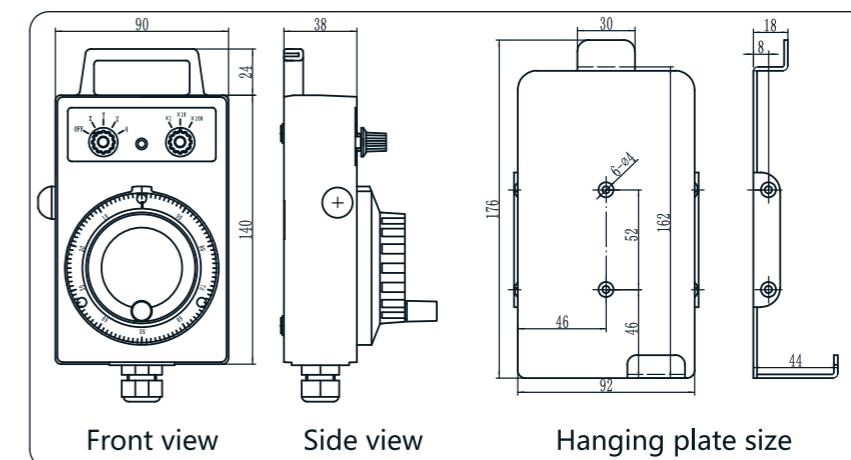

WIRING DIAGRAM

SE Series

S/N	Wire Color	Signal (Corresponding Type)	Signal (Coding Type)	Item
1	Red	+5V	+5V	Manual Pulse Generator
2	Black	0V	0V	
3	Yellow	HA	HA	
4	White	HB	HB	Differential selection
5	Pink	HA-	HA-	
6	Dark green	HB-	HB-	Input common port
7	Purple	COM	COM	
8	Yellow/Black	X1	R1	Magnification
9	Light Blue/Black	X10	R2	
10	Transparent/Black	X100	R4	
11	Brown	X	L1	Axis selection
12	Orange	Y	L2	
13	Pale blue	Z	L4	
14	Deep Blue	4	L8	
15	Transparent	-	-	Manual feeding
16	Pale purple	RAPID	RAPID	
17	Gray	+	+	Emergency stop
18	Red and white	EMG	EMG	
19	Red and black	EMGC	EMGC	
20	Light green	EMG1	EMG1	
21	Red and green	EMG1C	EMG1C	

SS/SM Series

S/N	Wire Color	Signal (Corresponding Type)	Signal (Coding Type)	Item
1	Red	+5V	+5V	Manual Pulse Generator
2	Black	0V	0V	
3	Yellow	HA	HA	
4	White	HB	HB	Differential selection
5	Pink	HA-	HA-	
6	Dark green	HB-	HB-	Input common port
7	Transparent	L+	L+	
8	Pale purple	L-	L-	Indicator light
9	Purple	COM	COM	Input common port
10	Yellow/Black	X1	R1	
11	Light Blue/Black	X10	R2	
12	Transparent/Black	X100	R4	Magnification
13	Gray	5		
14	Brown	X	L1	
15	Orange	Y	L2	
16	Pale blue	Z	L4	Axis selection
17	Deep Blue	4	L8	
18	Red and white	EMG	EMG	
19	Red and black	EMGC	EMGC	
20	Light green	EMG1	EMG1	Emergency stop
21	Red and green	EMG1C	EMG1C	

SF Series

S/N	Wire Color	Signal (Corresponding Type)	Item
1	Red	+5V	Manual Pulse Generator
2	Black	0V	
3	Yellow	HA	
4	White	HB	Differential selection
5	Pink	HA-	
6	Dark green	HB-	Input common port
7	Transparent	L+	
8	Pale purple	L-	Indicator light
9	Purple	COM	Input common port
10	Yellow/Black	X1	
11	Light Blue/Black	X10	
12	Transparent/Black	X100	Magnification
13	Gray	5	
14	Brown	X	
15	Orange	Y	
16	Pale blue	Z	Axis selection
17	Deep Blue	4	
18			
19			

CODING TABLE

Item	Gray code		
	L4	L2	L1
Axis selection	OFF	0	0
	X	0	1
	Y	0	1
	Z	0	1
	4	1	0
	5	1	1
	6	1	0
7	1	0	
Magnification	Gray code		
	R4	R2	R1
	X1	0	1
	X10	0	1
X100	0	1	
X1000	1	0	

Precautions

- 1. The color in the wiring diagram is for reference only, the specific use of color shall prevail.
- 2. The ends of spring cables are in the form of discrete wires with wire numbers and pressed in pin-type terminals by default. When the selection is P, the socket will not weld the wire and will be shipped with the goods. When the selection is P/XXM, the socket will weld XX meters of cable, and the other side of the loose wire will be pressed in 0508 pin-type terminal.
- 3. When the switching method is coding type, the coding method is Gray Code (the common terminal is 24V by default). If the common terminal is 0V or used in Yamamori matrix panel, it needs to be specified.
- 4. Accept customization.

PRODUCT FEATURES

- The core circuit board is controlled by a single-chip computer with matrix keyboard input;
- Universal shape design, more comfortable and beautiful hand feeling;
- High-performance core encoder, non-contact optical check-out structure;
- Built-in strong magnet, base type hanging box, more convenient and firm to place;
- High-quality standard spring cable, guaranteed 200,000 times stretching;
- Optional emergency stop, enable, and diversified key styles;
- Customized design is available according to customers' requirements.



APPLICATION AREAS

- Siemens, Mitsubishi, Fanuc, Guangzhou CNC, Huazhong CNC and other CNC systems
- Specialized automation equipment, CNC machine tools, printing machines, PLC control systems, etc.

OUTLINE DRAWING

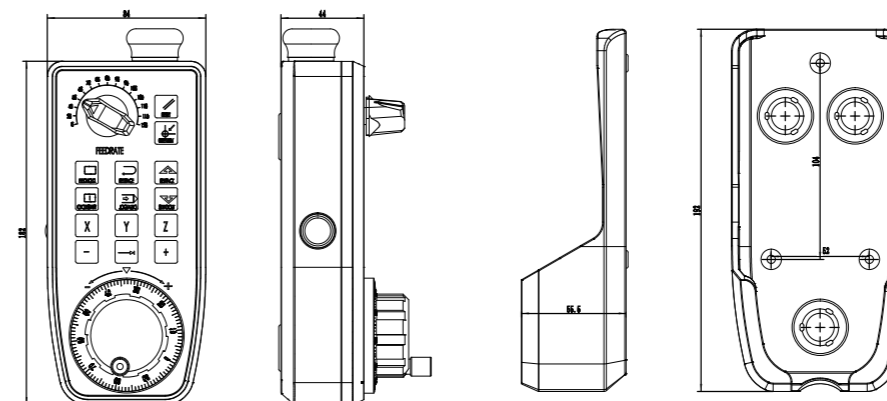

WIRING DIAGRAM

Aviation Outlet

	Pin No.	Code	Color
Input matrix	1	IN1	White and red
	2	IN2	White and green
	3	IN3	White and blue
	4	IN4	White and black
	5	IN5	White and brown
	6	IN6	White and purple
	7	IN7	Pale blue
	8	IN8	Orange
Output matrix	9	IN9	Gray
	10	01	Yellow and red
	11	02	Yellow and green
	12	03	Yellow and blue
	13	04	Yellow and black
	14	05	Transparent
	15	06	Transparent black
	16	07	Blue and black
Handwheel Signal	17	08	Blue and brown
	18	+5V	Red
	19	0V	Black
	20	HA	White
	21	HA-	Yellow
	22	HB	Green
	23	HB-	Purple
Emergency stop	24	EMG	Brown
	25	EMGC	Blue

INPUT SIGNAL ADDRESS TABLE OUTPUT SIGNAL ADDRESS TABLE

Address Matrix	IN5	IN4	IN3	IN2	IN1
Intermediate Address	M100.4	M100.3	M100.2	M100.1	M100.0
IN6					
Intermediate Address	M101.4	M101.3	M101.2	M101.1	M101.0
IN7					
Intermediate Address	M102.4	M102.3	M102.2	M102.1	M102.0
IN8					
Intermediate Address	M103.4	M103.3	M103.2	M103.1	M103.0
IN9		F0V8	F0V4	F0V2	F0V1

Address Matrix	08	07	06	05
Intermediate Address	M104.3	M104.2	M104.1	M104.0
01				
Intermediate Address	M105.3	M105.2	M105.1	M105.0
02				
Intermediate Address	M106.3	M106.2	M106.1	M106.0
03	X1			
Intermediate Address	M107.3	M107.2	M107.1	M107.0
04		X1000	X100	X10

Note: The wiring diagrams, input/output address lists, and key function definitions are customized for Siemens systems, and the specific wiring diagrams and address lists are based on the customer's system and functional requirements.

FEATURES IN BRIEF

- ◆ Adopting 433M wireless transmission technology, data encrypted transmission, stable and reliable, strong anti-interference;
- ◆ Wireless transmission distance 100 meters (open), stable and reliable;
- ◆ Response speed is fast, complete signal transmission and reception within 1ms;
- ◆ Low voltage alarm function, standby automatically enters the dormant mode;
- ◆ Adopting alloy encoder, stable and reliable performance; good hand feeling and clear tooth position;
- ◆ With emergency stop, enable, axis selection (max. 7 axes) and multiplier function;
- ◆ It has the functions of selecting axis selection and multiplier coding mode and selecting common terminal;
- ◆ 3.7v rechargeable lithium battery, low power consumption design, energy saving and environmental protection, random charging.

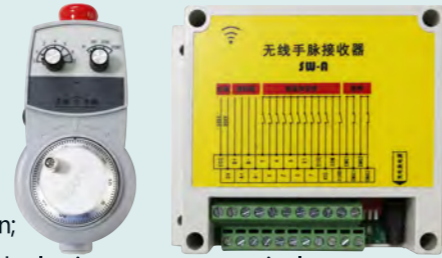

APPLICATION AREAS

- ◆ CNC lathes, CNC engraving and milling machines, machining centers, large gantry machines, laser cutting machines and other equipment
- ◆ Adapted to Siemens, Mitsubishi, Fanuc, Guangzhou CNC, Huazhong CNC, KND and other systems.

OUTLINE DRAWING

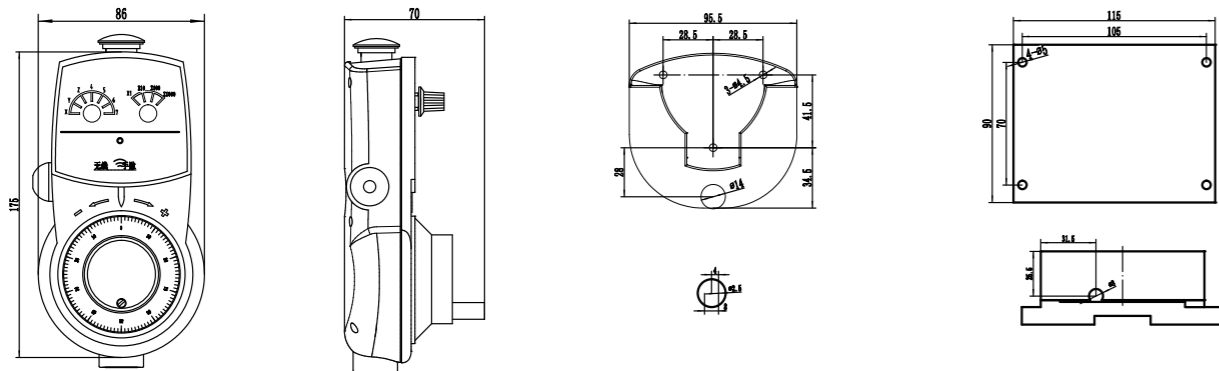

WIRING DIAGRAM

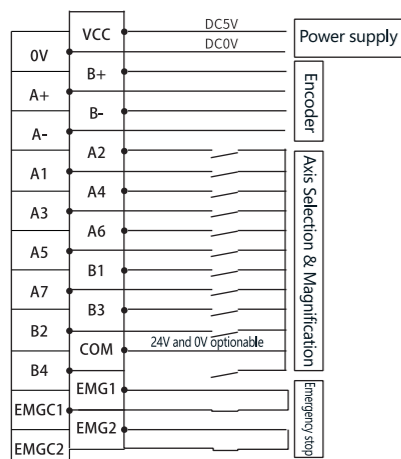

P2P STATUS TABLE

Terminal No.	X	Y	Z	4	5	6	7
A1	●						
A2		●					
A3			●				
A4				●			
A5					●		
A6						●	
A7							●

Terminal No.	X1	X10	X100	X1000
B1	●			
B2		●		
B3			●	
B4				●

GRAY CODE STATUS TABLE

Terminal No.	X	Y	Z	4	5	6	7
A1	●	●			●	●	
A2		●	●	●	●		
A3			●	●	●	●	●

Terminal No.	X1	X10	X100	X1000
B1	●	●		
B2		●	●	
B3			●	●



Switchboard Production & Assembly Site

In line with the concept of serving customers, SHANSEN CNC has launched the overall power distribution program, making OEM CNC machine tool distribution cabinets and switchboards, supporting the company's production of machine Operation Panels, safety door switches, hand-held pulse generators, warning lamps, work lights, intelligent electrical panels, relay modules, splitters, broken tool detector, oil mist collector, oil-water separator, center water equipment, complete sets of cables, etc., in order to facilitate the convenience of the customer! One-stop stocking.



Control Box & Assembly Site