

### FUNCTIONAL DESCRIPTION

Mechanical equipment in the processing, generally produces oil mist, water mist, pollution of the environment, jeopardizing the health of workers, reduce productivity, shorten the service life of the equipment. Installation of oil mist separator can eliminate oil mist, create a comfortable working environment and protect the health of workers.



### USE

The oil mist collector is used to purify and recycle the oil mist generated by various processing equipment. It has a wide range of applications and is suitable for fully enclosed and semi-enclosed processing equipment, such as CNC numerical control equipment, gear processing equipment, and is especially suitable for metal processing, sheet metal processing and welding, mold manufacturing, automotive parts manufacturing, fasteners production, and other manufacturing industry equipment.

### STRUCTURAL FEATURES

- ◆ 1. The oil mist collector adopts mechanical structure, adopts the principle of three-stage filtration and multi-stage precision to effectively collect and recover the oil mist, the collection rate is above 99%, and has excellent recovery efficiency for different concentrations of oil mist.
- ◆ 2. Multi-stage filtration method, filtration accuracy is constantly improving, effective collection and recovery equipment is stable and reliable, in line with industry standards JB/T12907-2016.
- ◆ 3. Low initial investment and later maintenance costs.
- ◆ 4. Low noise design <75dB(A), improve the quality of the workshop working environment.
- ◆ 5. Scientific design, simple structure, easy to install and maintain.
- ◆ 6. Further reduce the space occupation rate and improve the applicability of installation scenarios.
- ◆ 7. Flexible cartridge selection and matching mode, suitable for different applications.

### ADVANTAGES OF USE

- ◆ 1. Reduced impact on employees: Oil mist particles of 0.3 to 3.5 um can remain in the body, posing a health hazard.
- ◆ 2. Reduce workplace accidents: Oil mist deposition makes the work area, floor, and walkways slippery and prone to fall accidents.
- ◆ 3. Reduce the damage to mechanical equipment: a large amount of oil mist generated by high-speed cutting for a long time adsorbed on the equipment and workpiece, may become the cause of mechanical equipment and electrical system failure. To the maintenance of machinery and equipment work to bring a lot of trouble, but also make the processing accuracy of machinery and equipment is greatly reduced.
- ◆ 4. Reduce the consumption of coolant: the recovered oil mist can be reused, reducing the expenditure of coolant for the factory.
- ◆ 5. Reduce damage to the environment and waste of resources: If the oil mist gas is discharged to the outdoor, it will damage the environment and cause waste of resources.

### YWS2 SERIES

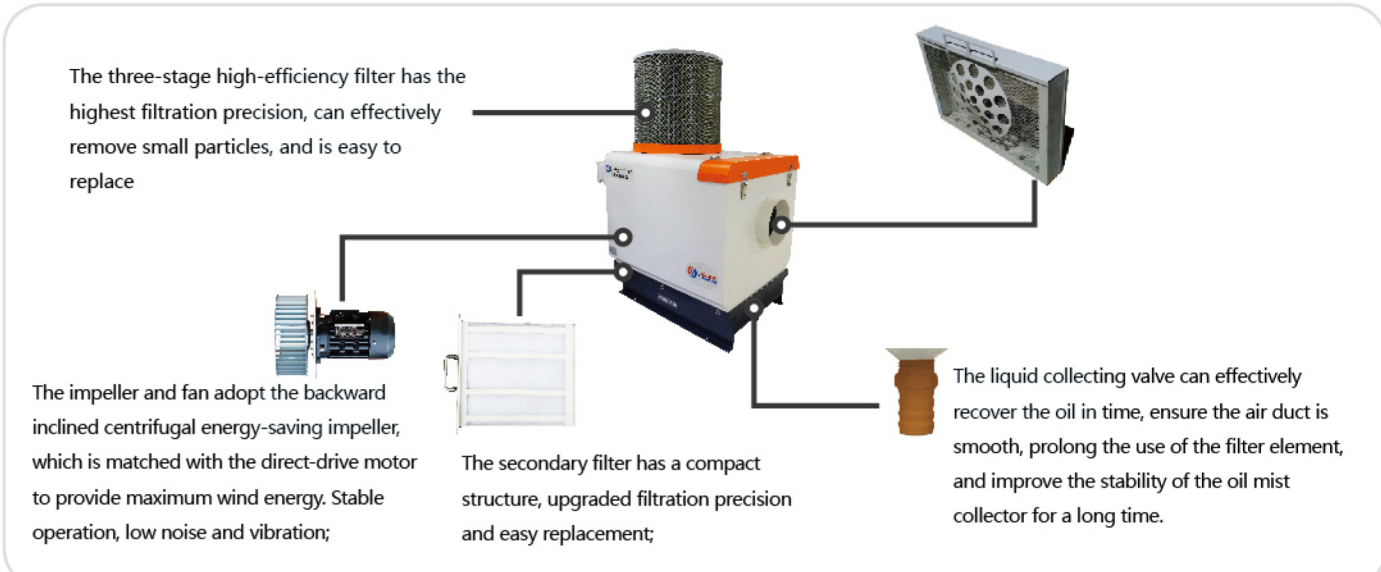

### MODEL SELECTION METHOD

According to the general use of the situation and the relevant standards of the machinery industry, you can refer to the following recommended values, the specific selection can be based on the actual use of the customer to choose the most appropriate model.

Closed Type	Oil Mist Models	Inlet Diameter(mm)	Air Volume	Door openings and closings per minute, general value (times/minute)	Suitable for processing room volume(m <sup>3</sup> )
	YWS2-55	Φ148	600	4~10	1~2.5
	YWS2-75	Φ148	800	4~10	1.5~3.5
	YWS2-150	Φ148	1000-1300	4~10	3~5
	YWS2-150A	Φ198	1300-1500	4~10	4~6
	YWS2-220	Φ148	1500-1800	4~10	5~7
	YWS2-220A	Φ198	1800-2100	4~10	7~10
	General Formula	Airflow = Volume*Opening Frequency*60			

Open-mouthed Type	Oil Mist Models	Inlet Diameter(mm)	Air Volume	Estimated air speed required to absorb oil mist, general value(m/s)	Suitable for the opening area of the processing room(m <sup>2</sup> )
	YWS2-55	Φ148	600	0.5<V<1	0.3~0.6
	YWS2-75	Φ148	800	0.5<V<1	0.4~0.8
	YWS2-150	Φ148	1000-1300	0.5<V<1	0.5~1.0
	YWS2-150A	Φ198	1300-1500	0.5<V<1	0.6~1.2
	YWS2-220	Φ148	1500-1800	0.5<V<1	0.9~1.8
	YWS2-220A	Φ198	1800-2100	0.5<V<1	1.1~2.2
	General Formula	Air volume = open area * estimated wind speed * 3600			

### MODEL DESCRIPTION

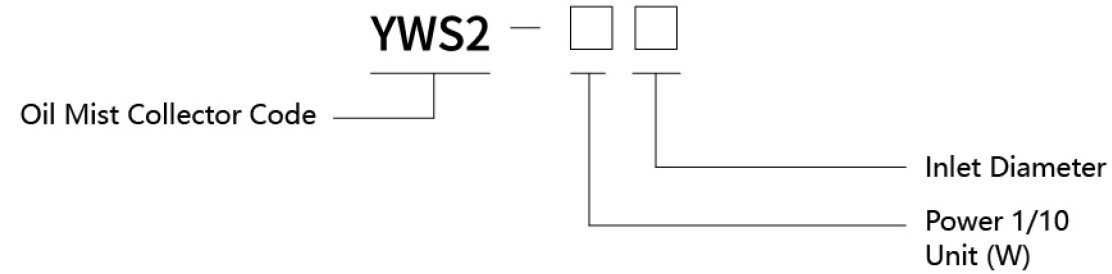

### PRODUCT PARAMETERS

Model No.	YWS2-55	YWS2-75	YWS2-150	YWS2-150A	YWS2-220	YWS2-220A
Power supply	3-phase, 220V/380V	3-phase, 220V/380V	3-phase, 220V/380V	3-phase, 220V/380V	3-phase, 220V/380V	3-phase, 220V/380V
Power (kW)	0.55	0.75	1.5	1.5	2.2	2.2
Rotating speed (R.P.M)	2740	2840	2840	2840	2840	2840
Current (A)	2.33/1.35	3.06/1.77	5.77/3.33	5.77/3.33	8.15/4.72	8.15/4.72
Air Volume (m <sup>3</sup> /h)	600	800	1000-1300	1300-1500	1500-1800	1800-2100
Noise dB (A)	66±2	66±2	68±2	68±2	68±2	68±2
Efficiency (%)	99	99	99	99	99	99
Inlet Diameter (mm)	Φ148	Φ148	Φ148	Φ198	Φ148	Φ198
Diameter of Oil Return Port (mm)	16	16	16	16	16	16
Element Material	Synthetic Fiber	Synthetic Fiber	Synthetic Fiber	Synthetic Fiber	Synthetic Fiber	Synthetic Fiber
Dimensions (L × W × H) (mm, without three-stage cartridge and holder)	610 × 400 × 530	630 × 410 × 550	640 × 450 × 586	640 × 450 × 586	640 × 450 × 586	655 × 450 × 586
Power Cord	4芯	4芯	4芯	4芯	4芯	4芯
Color	RAL9010 Customizable	RAL9010 Customizable	RAL9010 Customizable	RAL9010 Customizable	RAL9010 Customizable	RAL9010 Customizable

Note: Customers with special requirements for products support customization

### OPTIONAL ACCESSORIES



For different applications, three-stage HEPA filters can be selectively configured according to the needs and environmental requirements.

air inlet and oil return ducts (with appropriate size clamps), choose the appropriate length according to the installation location. Recommended to be purchased together with the oil mist collector.

Bracket (can be customized): Depending on the installation location, it is reasonable to decide whether or not the bracket needs to be installed. The oil mist collector is shipped with the oil mist collector by default.

### INSTALLATION METHOD

#### Top Mounting as Shown

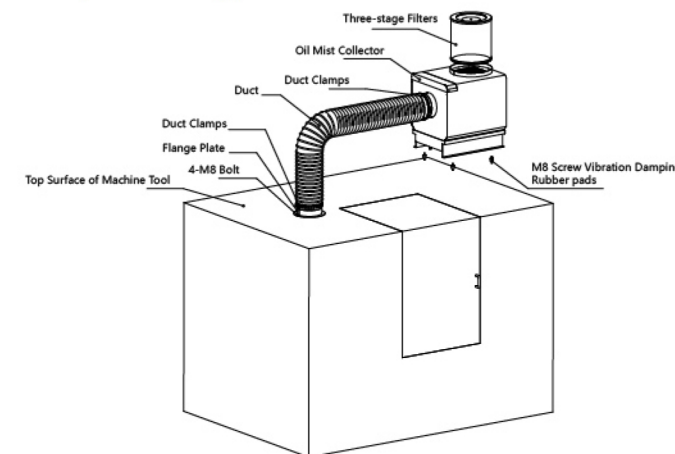

#### Side Mounting as Shown

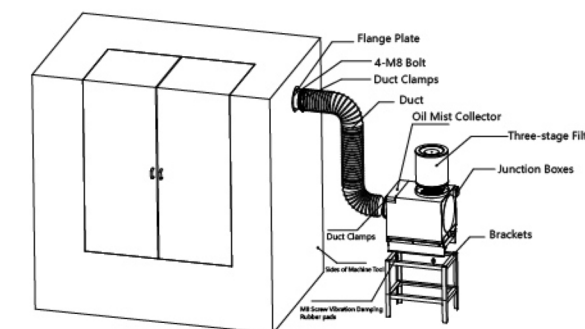

### COLLECTION METHOD

Centrifugal aggregation, return pipe return

### STRUCTURAL FEATURES

- Oil mist collector adopts mechanical centrifugal structure, using porous centrifugal impeller collision, fine filter cotton cohesion on the effective collection and recovery of oil mist, the collection rate of more than 99%, and for different concentrations of oil mist All have excellent recycling efficiency.
- High working efficiency, high filtration precision, effective collection and recycling.
- The equipment is stable and reliable, and complies with the industry standard JB/T12907-2016.
- Low upfront investment and post maintenance costs.
- Low noise design to improve the quality of workshop working environment.
- Scientific design, simple structure, easy to install and maintain.



### ADVANTAGES

- Reduce the impact on employees: 0.3-3.5um oil mist particles are inhaled and difficult to expel, jeopardizing health.
- Reduces workplace accidents: Oil mist deposits make work areas and floors slippery and prone to fall accidents.
- Reduced damage to machinery and equipment: oil mist adsorbed on equipment and workpieces for long periods of time can lead to mechanical and electrical system failures. Obstacles. Affects the work of mechanical equipment and reduces the machining accuracy of mechanical equipment.
- Reduce the consumption of coolant: the recovered oil can be reused, reducing the cost of the enterprise.
- Reduces environmental damage and resource waste: Oil mist discharged into the air damages the environment and also causes resource waste.
- Reduces environmental damage and resource waste: Oil mist discharged into the air damages the environment and also causes resource waste.

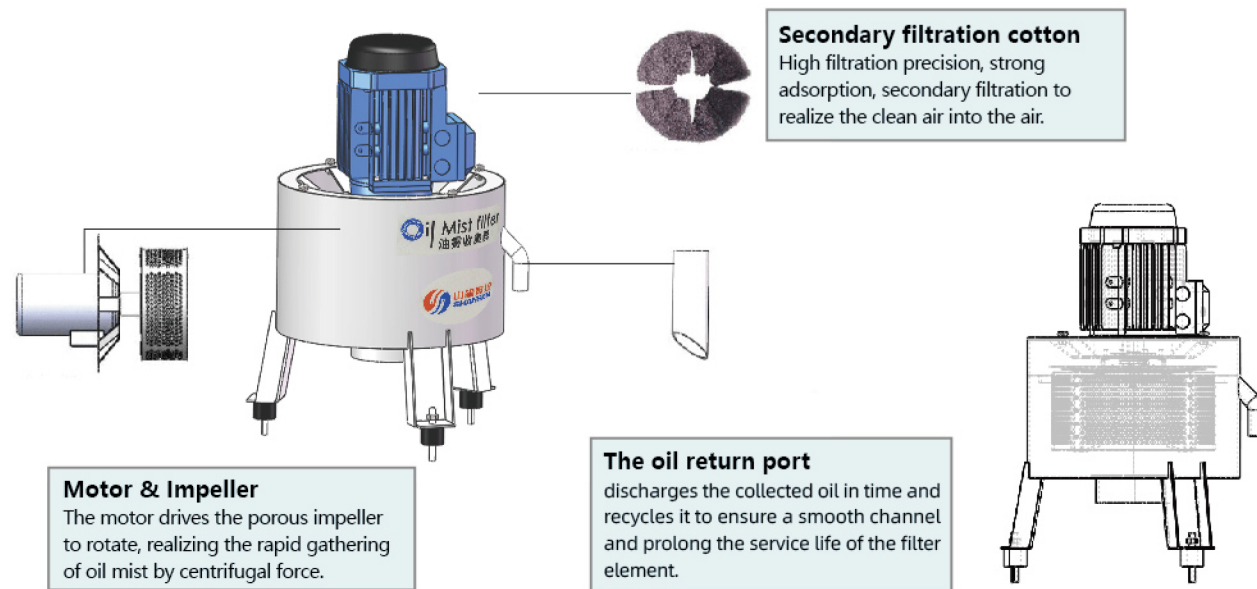

### CONSUMABLES REPLACEMENT



Unscrew the Allen screws and remove the secondary filter wool for replacement.

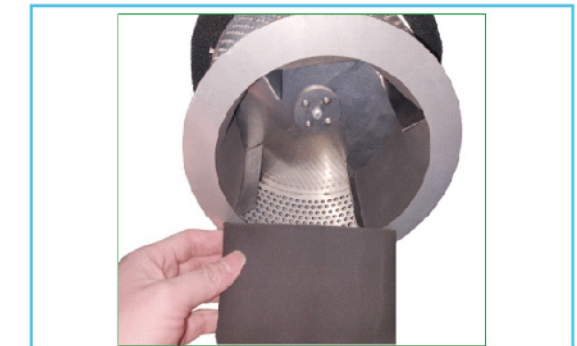

Remove the fine filter wool directly for replacement.

### MODEL SELECTION METHOD

According to the general use of the situation and the relevant standards of the machinery industry, you can refer to the following recommended values, the specific selection can be based on the actual use of the customer to choose the most suitable model.

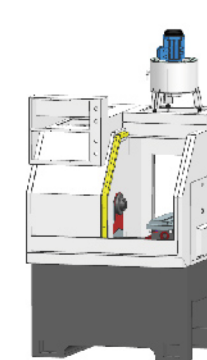

	Oil Mist Models	Air Volume	Door openings and closings per minute, general value (times/minute)	Suitable for processing room volume(m³)
Closed Type	YWV1-12	400	4~10	0.5~1
	YWV1-37	600	4~10	1~2
General Formula	Airflow = Volume*Opening Frequency*60			

	Oil Mist Models	Air Volume	Estimated air speed required to absorb oil mist, general value(m/s)	Suitable for the opening area of the processing room(m²)
Open-mouthed	YWV1-12	400	0.5<V<1	0.05~0.1
	YWV1-37	600	0.5<V<1	0.1~0.15
General Formula	Open Area * Estimated Wind Speed * 3600			

### CLOSED-ENDED TYPE CALCULATION METHOD

**Q—Oil mist collector air volume, in cubic meters per hour (m³ / h);**

W×D×H—The volume of the processing chamber cavity (length×width×height), unit is meter (m)

a—The number of air changes per minute in the processing room, in units of times per minute (times/min).

### OPEN-ENDED TYPE CALCULATION METHOD

**Q—Oil mist collector air volume, in cubic meters per hour (m³ / h);**

A x B—Opening size of the processing chamber (length x width), in meters (m)

V—Oil mist suction is expected to require wind speed, the unit is meters per second (m/s), generally more than 0.5m/s